

## PHOSPHORUS PENTOXIDE (P<sub>2</sub>O<sub>5</sub>) MOISTURE SENSOR

The electrolytic moisture sensor used by Systech Instruments employs the well known phosphorus pentoxide principle for accurate determination of trace levels of moisture in inert gas streams.



### THEORY

Following from Faraday's Law of electrolysis, water molecules require a known amount of energy to dissociate into hydrogen and oxygen. The electrolytic sensor passes a known voltage along an electrode coated with a water-absorbing chemical. When the water comes into contact with the electrode it absorbs energy and dissociates. The amount of energy absorbed is directly related to the amount of water present in the gas stream.

A constant voltage is applied across the windings and the resultant current is monitored. As a flow of gas passes over the sensor, the moisture in the gas stream is attracted to the P<sub>2</sub>O<sub>5</sub> coating, changing the resistance between two platinum coils. The resistance changes due to the moisture, which is then electrolysed into hydrogen and oxygen gases. The change in resistance creates a change in the measured current.

This electrical current, according to Faraday's law, is directly proportional to the amount of moisture in the gas stream. Therefore, a knowledge of the gas flow rate through the sensor and the current in the cell gives an absolute measure of the moisture contained in the sample gas. The mathematical equation for this measurement is:

$$I = K_1 F C + (e + B)$$

where:

- I = Current
- K<sub>1</sub> = Faraday's Constant
- F = Mass Flow
- C = Moisture Content of Gas
- e = Electrolytic Background Current
- B = Recombination Current

### Principle of Operation

The phosphorus pentoxide (P<sub>2</sub>O<sub>5</sub>) moisture sensor consists of a dual platinum winding formed around a quartz tube about 8cm long. The extremities of the windings are sealed by a resin coating. The bare platinum electrodes are coated with a thin film of P<sub>2</sub>O<sub>5</sub>. PTFE guides are provided at each end of the sensor through which the electrical connections to the windings protrude. A constant voltage is applied across the windings and the resultant current is monitored. As a flow of gas is passed over the sensor, the moisture in the gas stream is attracted to the P<sub>2</sub>O<sub>5</sub> coating, changing the resistance of the platinum coil. The resistance changes due to the moisture being electrolysed into hydrogen and oxygen gases. The change in resistance creates a change in the measured current. This electrical current, according to Faraday's law, is directly proportional to the amount of moisture in the gas stream. Therefore, a knowledge of the gas flow rate through the sensor and the current in the cell gives an absolute measure of the moisture contained in the sample gas.

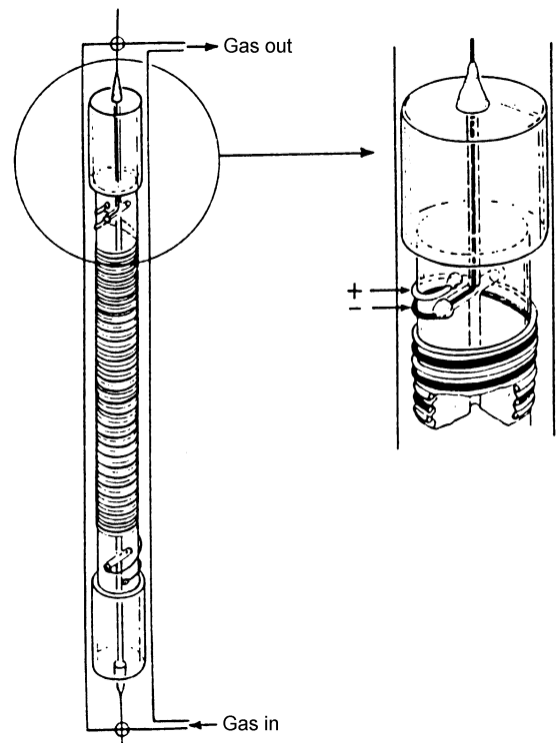

## Principle of Operation (cont)

An effect called recombination can occur if the carrier gas contains hydrogen or oxygen. This is usually only a problem if the measured sample contains less than 5 ppm of moisture. Recombination occurs because the hydrogen or oxygen in the sample gas stream will combine with the hydrogen and oxygen being produced during electrolysis to form another water molecule. This water molecule is attracted again to the sensor and electrolysed again, reducing the resistance and producing a falsely high reading.

If recombination is suspected, it can easily be checked by doubling the flow rate of the sample gas. The higher flow rate will clear the electrolysis products from the sensor faster, so reducing the recombination. Without recombination, doubling the flow of sample gas should exactly double the moisture reading. If the reading does not exactly double, then recombination exists. To compensate for the recombination and calculate the true moisture reading, use the following formula:

$$\text{true moisture (ppm)} = \text{reading at 200cc/min} - \text{reading at 100cc/min}$$

Systech analysers contain built in, automatic, compensation for use in hydrogen and oxygen containing gas streams.

## Cell Recoating

The P<sub>2</sub>O<sub>5</sub> coating on the cells is slowly consumed as the cell operates, ultimately the cell will no longer respond to moisture and will require recoating. Recoating the cells is a simple process whereby a dilute solution of phosphoric acid is applied to the windings. For maximum cell lifetime it is recommended that the cells are purged with clean, dry gas when not in use.

## Calibration

Because this measurement principle is a primary measurement method (absolute measurement following scientific law), no calibration is required.

However it is important to ensure the flow rate of the gas stream is a constant, known value. Mass Flow Controllers are available for most instruments to ensure the flow rate remains constant.

## Applications

Inert gases typically used with this type of instruments include argon, nitrogen, and helium.

The applications for the moisture analysers fall into two industrial areas:

- Gas Producers - for ensuring product quality
- Gas Users - process gas monitoring  
(The Pharmacopoeia requires use of P<sub>2</sub>O<sub>5</sub> for measurements of medical oxygen)

Typical industries are Semiconductor manufacturing, Medical gases, Nuclear processing and Plastics.

The P<sub>2</sub>O<sub>5</sub> moisture analysers are not suitable for measurement of moisture in gases or gas mixtures that will react with the phosphorus pentoxide in the detection cell. Such gases include acetylene, butylene, carbon dioxide, hydrogen sulphide, and propylene. In addition, gas mixtures containing compounds which will attack the cell components must be avoided. Systech can provide special cells with a glass housing which are suitable for measurements in corrosive gases such as chlorine (Cl<sub>2</sub>) and hydrogen chloride (HCl)

Oxygen and hydrogen cause interference with the moisture measurement. Refer to "Recombination" above for further information regarding moisture measurements in these gases.

Systech Instruments Ltd  
17 Thame Park Business Centre,  
Thame  
OXON  
UK  
OX9 3XA

www.systech.co.uk  
email advice@systech.co.uk  
Fax +44 1844 217 220  
Tel +44 1844 216 838